

Hexoloy[®] Silicon Carbide Chemical Process Heat Exchanger Tubing



A superior alternative to metals, glass and other tube materials for enhanced heat exchanger efficiency, uptime and reliability

- High Thermal Conductivity
- Virtually Universal Corrosion Resistance
- Extreme Hardness and High Strength

Hexoloy[®] SiC Heat Exchanger Tubes give you distinct advantages

Saint-Gobain offers Hexoloy silicon carbide chemical process heat exchanger tubing as a superior alternative to tubes made of metals, glass and other materials. Hexoloy SiC is a single-phase, sintered alpha silicon carbide offering high purity, fine grain size and extremely low porosity. Hexoloy SiC tubes offer distinct advantages to enhance the performance of shell and tube heat exchangers used in demanding applications from chemical processing to refineries.

Excellent Thermal Conductivity

Hexoloy SiC's thermal conductivity is almost equal to that of commonly used graphite tubes and far better than all other tube materials available. Its thermal conductivity is twice that of tantalum, 5 times that of stainless steel, 10 times that of Hastelloy and 15 times that of glass. The result is higher efficiency while requiring less heat transfer area.

Meets Tough Standards

Hexoloy SA SiC is approved for use by the following authorities:

- WRC, Water Byelaws Scheme (U.K.)
- DVGW, German Federal Health Office
- FDA, Non Food Additive

Thermal Conductivity

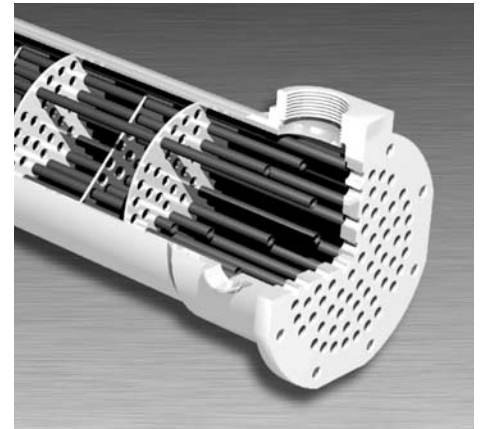
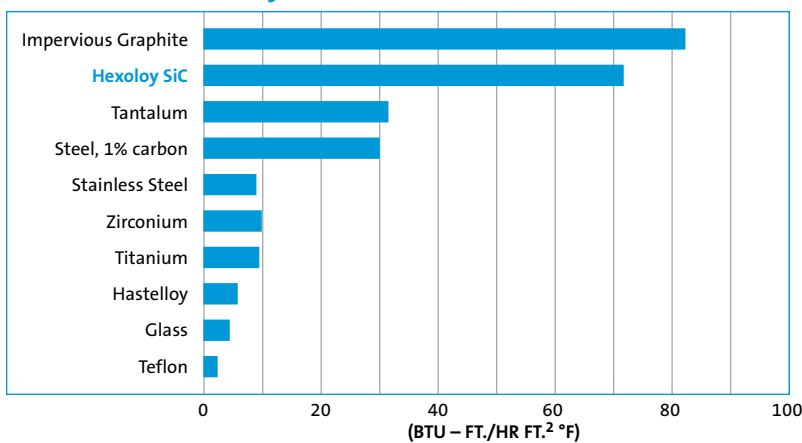

Hexoloy[®] Silicon Carbide

Virtually Universal Corrosion Resistance

Hexoloy SiC is **universally corrosion resistant** against virtually all chemicals even up to 400° F. Hexoloy SiC tubes have been proven for years in HF, bromine, high concentration nitric, mixed acids, bases, oxidants and chlorinated organics.

Typical Corrosion Resistance

Corrosive Medium	Temperature °F (°C)	Hexoloy Corrosion Rate (mg/cm ² YR)
98% H ₂ SO ₄	212 (100)	1.8
85% H ₃ PO ₄	212 (100)	<0.2
53% HF	77 (25)	<0.2
50% NaOH	212 (100)	2.5
45% KOH	212 (100)	<0.2
70% HNO ₃	212 (100)	<0.2
37% HCl	187 (86)	<0.2
10% HF plus 57% HNO ₃	77 (25)	<0.2

Extreme Hardness and High Strength

Hexoloy SiC is one of the hardest high performance materials available for heat exchanger tubes. Its density is in excess of 98% of theoretical and Hexoloy SiC is completely impervious without the use of any impregnants. It is 50% harder than tungsten carbide, so it offers superb wear resistance and total impermeability at extreme temperature and pressure, and allows higher velocity and improved heat transfer. In fact, **every Hexoloy heat exchanger tube is proof tested to 186 bar (2,700 psi)** to assure reliability and added safety. Hexoloy SiC's extreme hardness also means no contamination in high purity applications.

Hexoloy SiC heat exchanger tube sizes

Saint-Gobain supplies Hexoloy SiC heat exchanger tubes in lengths in excess of 4.5 meters and in 12.7 mm, 14 mm, and 19 mm outside diameters to meet specific heat exchanger needs.

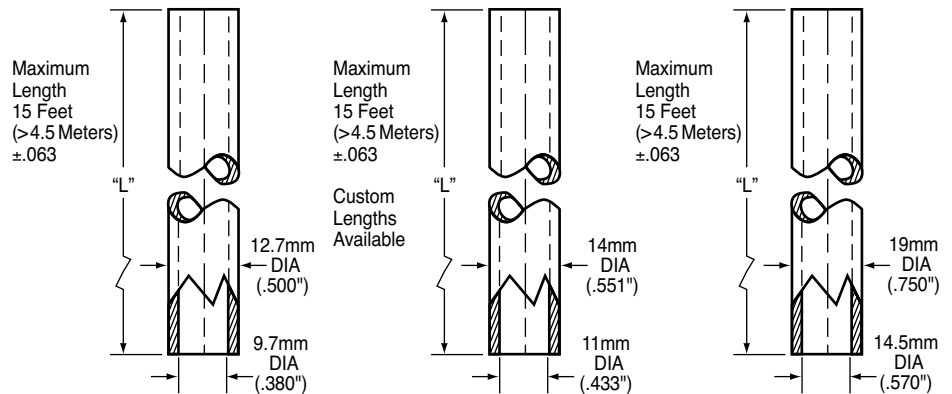

Standard Tube Dimensions

Physical Properties of Hexoloy SiC Materials

Hexoloy SiC Grade SA – Typical Values

Physical Properties	Units	SA
Composition (phases)		SiC
Density	g/cm ³	3.10
Grain Size	microns	4-10
Hardness (Knoop)*	kg/mm ²	2800
Flexural Strength 4pt. @ RT**	MPa x 10 ³ lb/in ²	380 55
Compressive Strength @ RT	MPa x 10 ³ lb/in ²	3900 560
Modulus of Elasticity @ RT	GPa x 10 ⁶ lb/in	410 59
Weibull Modulus (2 parameters)		8
Poisson Ratio		0.14
Fracture Toughness @ RT Double Torsion & SENB	MPa/√m 10 ³ lb /in ² /√in	4.60 4.20
Coefficient of Thermal Expansion RT to 700°C	x 10 ⁻⁶ mm/mm°K x 10 ⁻⁶ in/in°F	4.02 2.20
Max. Service Temp (air)	°C °F	1900 3450
Mean Specific Heat @ RT	J/gm°K	0.67
Thermal Conductivity @ RT	W/m°K Btu/ft h°F	125.6 72.6
@ 200°C		102.6 59.3
@ 400°C		77.5 44.8
Permeability RT to 1000°C		All impervious to gases over 31 MPa
Electrical Resistivity @ RT*** @ 1000°C	ohm-cm	10 ² -10 ⁸ 0.01-0.2
Emissivity		0.9

* Knoop 100-gm load

** Test Bar Size: 3 x 4 x 45 mm (0.118" x 0.157" x 1.772")

*** Dependent upon dopants in Hexoloy SA SiC that will decrease electrical resistivity to a desired range.

N/A = Not applicable or not available

Specify Hexoloy SiC Tubes for Your Shell and Tube Heat Exchangers

For more information on Hexoloy SiC heat exchanger tubes, contact Saint-Gobain Ceramics or your heat exchanger OEM. Or ask your supplier about retrofitting your existing heat exchangers with Hexoloy SiC tubes.

Visit www.carbo.com for more information.

United States

Saint-Gobain Ceramics

23 Acheson Drive
Niagara Falls, NY 14303
Tel: 716-278-6233
Fax: 716-278-2373
e-mail: scd.sales@saint-gobain.com
www.carbo.com

Germany

Saint-Gobain Advanced Ceramics GmbH

Postfach 401254 • Nobelstrasse 6
41189 Mönchengladbach, Germany
Tel: 49-(0)-2166-55090
Fax: 49-(0)-21665-509-10

Japan

Saint-Gobain Ceramics SC

3-7, Kojimachi, Chiyoda-Ku,
Tokyo 102-0083, Japan
Telephone: 81-3-3263-0289
Fax: 81-3-3264-6010

Hexoloy® is a registered trademark of Saint-Gobain Ceramics

©2005 Saint-Gobain Ceramics
All Rights Reserved
Replaces Form No. A-12090
Form No. B-1059
9/05

The information recommendations, and opinions set forth herein are offered solely for your consideration, inquiry and verification and are not, in part or total, to be construed as constituting a warranty or representation for which we assume legal responsibility. Nothing contained herein is to be interpreted as authorization to practice a patented invention without a license.